

# Air Conditioning

## Product Information

### PEA-RP500GAQ : Standard Inverter Heat Pump

R410A Large Capacity Ceiling Concealed Ducted System



The Standard Inverter range offers customers all the features and benefits of inverter technology whilst being cost effective

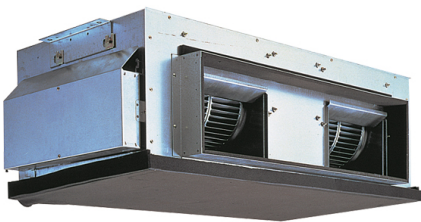

## FEATURES



### INDOOR

Heating Capacity (kW) (nominal)	54.0 (25-63)
Cooling Capacity (kW) (nominal)	44 (22.4-56)
Heating Capacity (kW) (UK)	45.9 (21.25-53.55)
Cooling Capacity (kW) (UK)	40.5 (20.6-51.5)
SHF (nominal & UK)	0.77
COP / EER (Nominal)	3.10 / 2.53
Energy Label Heating / Cooling (nominal)	D / E
Airflow (m <sup>3</sup> /min)	160
Pipe Size Gas (mm [in])	28.58 (1 1/8") X2
Pipe Size Liquid (mm [in])	12.7 (1/2") X2
External Static Pressure (Pa)	150
Sound Pressure Level (dBA)	53
Dimensions (mm) Width x Depth x Height	1947 x 764 x 595
Weight (kg)	133
Electrical Supply	380-415V, 50HZ
Phase	THREE
Power Input (kW) nominal / UK	2.84 / 2.53
Starting Current (A)	10
Running Current (A) [MAX]	5.4 [6.5]
Fuse Rating (BS88) - HRC (A)	10
Mains Cable No. Cores	5
Interconnecting Cable No. Cores	3

### OUTDOOR

Sound Pressure Level (dBA) Heating / Cooling	59 / 59
Weight (kg)	135
Dimensions (mm) Width x Depth x Height	950 x (330+30) x 1350
Electrical Supply	380-415V, 50HZ
Phase	THREE
System Power Input (kW) Heating / Cooling (nominal)	17.42 / 17.36
System Power Input (kW) Heating / Cooling (UK)	15.50 / 14.76
Starting Current (A)	5
System Running Current (A) Heating / Cooling [MAX]	12.00 / 11.00 [21.0]
Fuse Rating (BS88) - HRC (A)	25
Mains Cable No. Cores	5
Max Pipe Length (m)	70
Max Height Difference (m)	30
Charge R410A (kg) - Pre-charged Length (m)	7.1 - 30

### DIMENSIONS

PEA-RP500GAQ

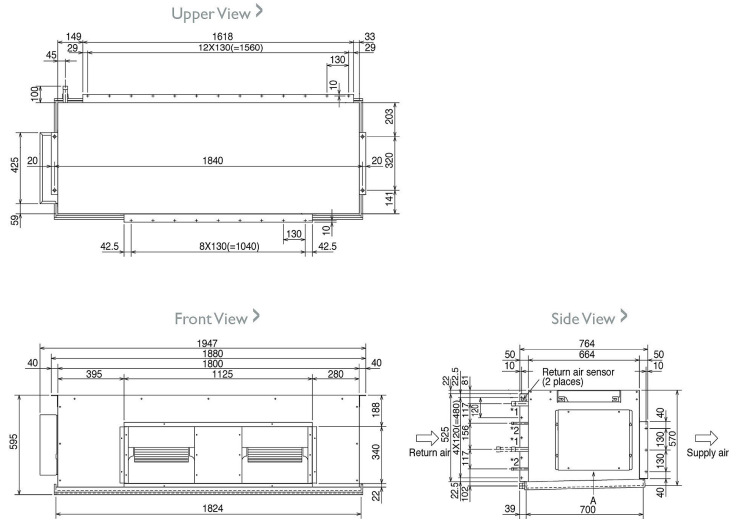

### DIMENSIONS

PUHZ-P250YHA3

